



LEDGE
GRILL

The WHY is found in the thoughtful design.

CAUTION
SURFACE MAY BE HOT



THE NEW INDUSTRY STANDARD
PRIME 2.0

Green Mountain knows pellet grills. We built our new and improved Prime 2.0 models to precise standards. You will get a high quality, innovative barbecue designed to provide years and years of reliable service. GMG tames the fire so much better than anyone in this industry.

GMG has your back with solid technical support, a 3-year warranty, and nearly two decades of pellet grill experience. Our boss is the customer.



PEAK PRIME 2.0

- WiFi Smart Control
- 12V Direct Power
- 150°-550°F Temp Range
- RACKT™ Technology
- 738 sq. in. Grill Space
- Up to 1,386 sq. in. w/ RACKT™
- 20 LB Hopper Capacity

FULL PRODUCT DETAILS [→](#)



LEDGE PRIME 2.0

- WiFi Smart Control
- 12V Direct Power
- 150°-550°F Temp Range
- RACKT™ Technology
- 530 sq. in. Grill Space
- Up to 962 sq. in. w/ RACKT™
- 20 LB Hopper Capacity

FULL PRODUCT DETAILS [→](#)



TREK PRIME 2.0

- WiFi Smart Control
- 12V Direct Power
- 150°-550°F Temp Range
- RACKT™ Technology
- 274 sq. in. Grill Space
- 10 LB Hopper Capacity

FULL PRODUCT DETAILS [→](#)



Grilling made easy



DUAL VOLTAGE AC+DC POWER DESIGN

GMG is the only grill on the market that can run either alternating or direct current straight from dual ports on the grill. You can run your grill from any power source 12v or 110v (220v outside North and South America).

Our direct-current, high-torque motor assures long-term, reliable performance and low energy consumption. With 32 lbs. of torque the auger motor allows you to bust through the most difficult jamming. The 3800 RPM fan motor gives you full control of temperatures from 150 to 550°F with 5 degree increments.

INDUSTRY LEADING SMART CONTROL

It starts with a simple yet elegant control board design that gives you full control and comfort at your grill. GMG's state of the art microprocessor ensures that the grill works right every time. Have two different foods cooking? No problem. Two food probe ports let you keep track of the internal temperature of both. Equipped with a low pellet alarm to help keep wood on the fire and an external USB port that lets you charge other devices, too.

For the novice to the most tech savvy, GMG Prime 2.0 App is truly unparalleled in the pellet world. With dual connections (WiFi and Bluetooth) it keeps you solidly in touch with your cook. Worldwide AWS servers allow you to observe conditions inside the grill from literally anywhere. We didn't create an app to blast you with ads. We created this app for you to control your grill and access innovative features that elevate your grilling experience. For instance Profiles, like programmable recipes, allow you to create steps throughout your cook and save/edit them later to replicate your favorite techniques. We have some of the best competition pitmasters in the industry creating their own Profiles that you can download and try out for yourself. Perfecting your BBQ craft has never been easier. More features include a pizza mode and cold smoke mode along with full graphing which can also be exported. Equipped with full calibration tools for operating in extreme weather conditions to calibrating your meat probes and third party devices.

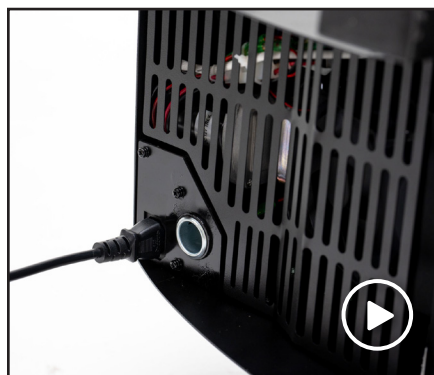

PRECISELY DESIGNED **FIRE & SMOKE MANAGEMENT**

GMG knows the FIRE. We know how to achieve 150°F and give you the most clean burning smoke at the lowest temperature in the entire industry. You can also accelerate temperatures to 550°F in 5 degree increments in a breeze. Our Venturi-Style firebox circulates air around the outside of the pellets to ensure an even burn and constant temperature throughout the grill.

GMG knows the fire so well that we even give our users complete control over left to right temperatures with our externally adjustable heatshield. Why is this important? Do you have some ribs or chicken cooking and want to get started on the veggies or cook multiple meats at the same time? Easy! Slightly adjust the heatshield left or right, mid-cook, to channel more heat to one side and then right back to center to balance it out. GMG is the only pellet grill in the industry with this type of external side to side heat control.

Our grills are equipped with a Cold Smoke Mode that allows you to achieve true cold smoking temps. The grill continuously runs the fan without producing heat from the firebox providing even cold smoke distribution with the use of a smoke tube.

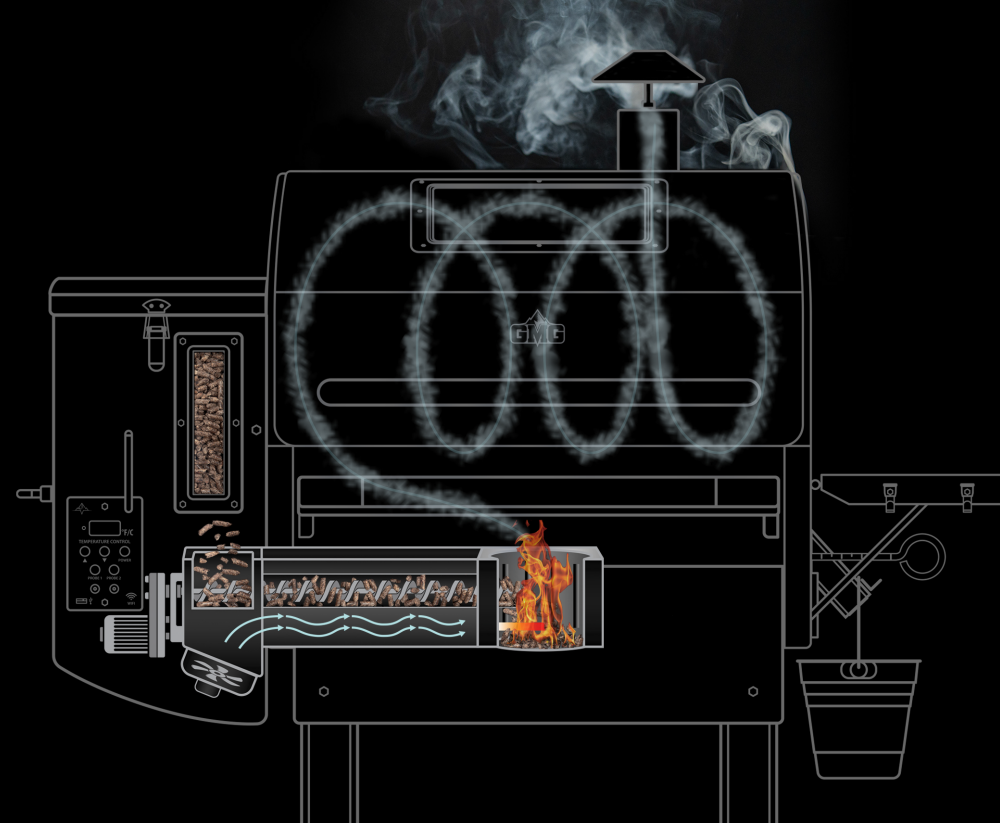

EXTERNALLY DRIVEN **GREASE SYSTEM**

Grease management is very important. It is imperative to move grease outside of the grill. For that reason, we have designed our units with a sloped grease tray that moves the grease into a trough. From there the grease spouts down into an EXTERNAL bucket that we have secured onto the OUTSIDE of the grill.

USER DRIVEN **ASHVAC™ SYSTEM**

We've made firebox clean-out effortless with our AshVac™ system. We have engineered a trap door to attach a shop vac, when the unit is cool, to pull the ash from the firebox.

PELLET MANAGEMENT

We have made cleaning out the hopper and swapping your pellet blends a breeze with a rear pellet dump door.

See how easy maintenance is 

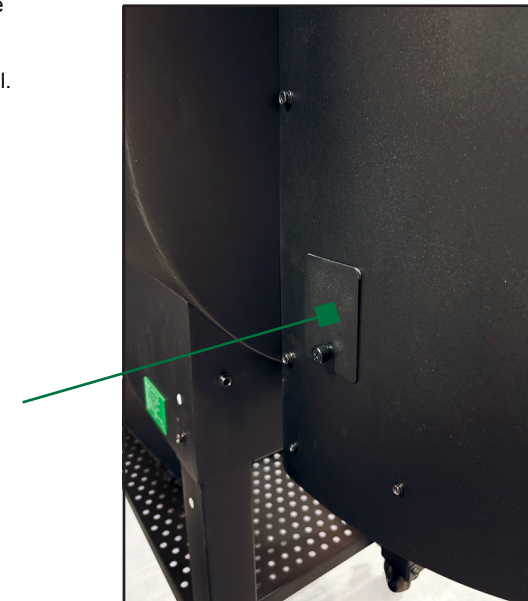
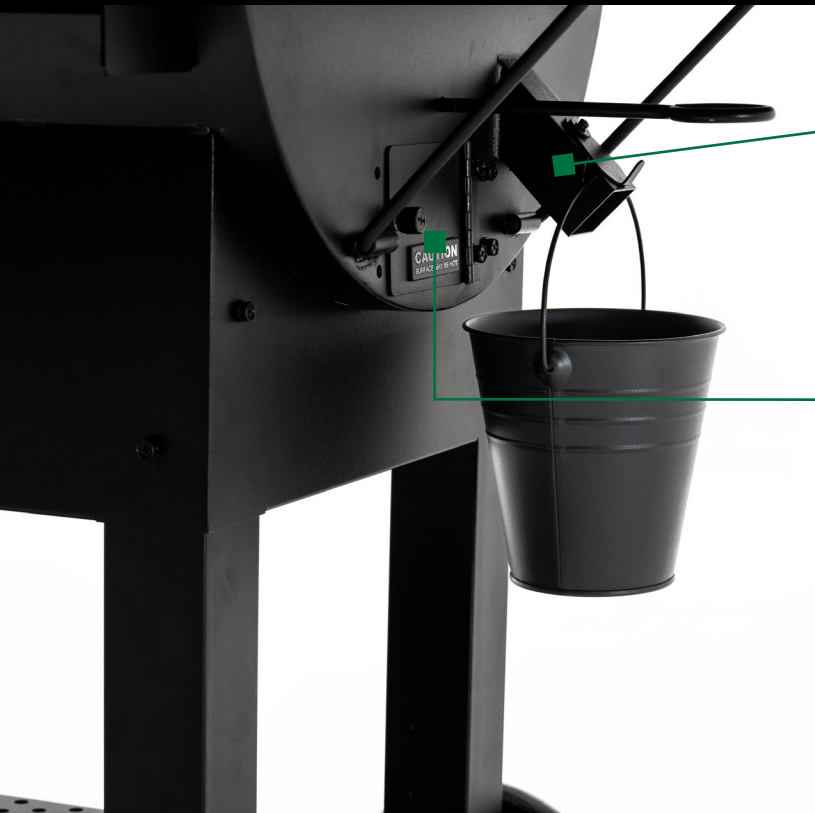



INDUSTRY INNOVATING
WOOD-FIRED ACCESSORIES

GMG designed, developed, and patented the very first pellet grill pizza oven. If you've never eaten a true wood-fired pizza that took less than 5 minutes to bake, you are in for a treat. However tasty you hope it will be; it will be better!

The SideBURN™ is a true carbon-coil infrared touchscreen burner with a range of temperatures from simmer to ultra-hot. It is NOT an induction burner. Sear a steak better than a fancy restaurant or just keep stuff warm! It comes with a two-sided sear plate (ribbed or flat) for just about anything you need to cook on it.

Our Ledge and Peak models have been rotisserie-enabled for many years. You can grill and enjoy a far better rotisserie chicken than any store-bought one you've ever had. Or do a turkey or a roast or a ham! You will not believe how moist and tender your food is when you use this accessory.



PIZZA ATTACHMENT



SIDEBURN™

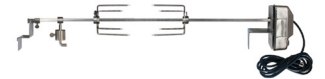

ROTISSERIE



TREK CART



BBQ MAT



PIZZA PEEL



INDUSTRY FIRST
RACKT™ SYSTEM

Our Ledge and Peak Prime 2.0's come with a revolutionary racking technology RACKT™ that allows you to **CUSTOMIZE & MAXIMIZE** your grilling space. The backboard is designed for easy plug & play connection of different RACKT™ accessories to tailor your cooks. The smoke racks elevate your food and maximize your grill space to nearly 1000 sq. in. on the Ledge 2.0 and 1400 sq. in. on the Peak 2.0. Don't worry, we still leave you with easy to access bottom grate space up front. The rib rack lets you grill up to 4 racks of ribs upright for even smoke penetration and exposure to both sides of it simultaneously. The griddle makes breakfast or burgers easy. The chicken leg/drumette holder provides a neat and tidy way to grill these delicious treats. Wood-fired versatility is endless with RACKT™.



RACKT™ BACKBOARD



SMOKE RACK



RIB RACK



GRIDDLE



CHICKEN HOLDER



PEAK PRIME 2.0



ALL-WEATHER COVERS & THERMALS

We've built and tested our form-fitted grill covers to withstand the toughest weather conditions. Our covers have a 500D heavy-duty polyester, all-weather, waterproof and anti-UV design with breathable netting panels to prevent moisture buildup. Protect your investment with a custom GMG cover designed to keep your grill happy and looking good!

Keep your grill warm in the wintertime and cut your pellet usage by up to 25% with our form-fitted, heavy-duty silica gel cloth & ceramic fiber thermal blankets. They are all-weather, waterproof, and heat-resistant.

Both our covers and thermal blankets are designed with re-positionable chimney flaps to fit all Choice, Prime & Prime 2.0 models.

INDUSTRY LEADING **DURABILITY**

Large all-terrain hard rubber tires and locking caster wheels make it easy to move the grill when you need to and hold sturdy in place when grilling. The straight leg design allows you to move the unit without destroying your legs or shins.

The GMG Prime 2.0 line is extremely well built. The Ledge at nearly 210 lbs. and the Peak at nearly 250 lbs. will amaze you with their sturdiness. We have also added steel ribs inside the grill at the sides to strengthen the lid and also to hold smoke better.

GMG believes in the durability of stainless steel. We've built the most critical parts, that contact fire, out of premium stainless steel including the firebox, rail system with our adjustable heatshield, and grease tray.



THOUGHTFULLY DESIGNED **CONVENIENCE & STORAGE**

GMG gives you some elbow room with a folding front shelf, side shelf, and a full bottom rack for plenty of storage on all Ledge and Peak 2.0's.

EASY TO FOLLOW **3D ASSEMBLY**

Our Prime 2.0 line was engineered with our customers in mind from assembly to operation. We partnered with BILT Intelligent Instructions to provide you with a very easy to follow 3D interactive assembly. It takes you through unboxing to completion with the ability to zoom in/out and rotate the unit on screen to get an immersive understanding of the grills assembly and design. Check out the BILT app today to see how the full assembly takes place. BILT also gives you easy access to all safety info, operating manual, and ability to register your warranty.

POWERED BY
BILT INTELLIGENT
INSTRUCTIONS

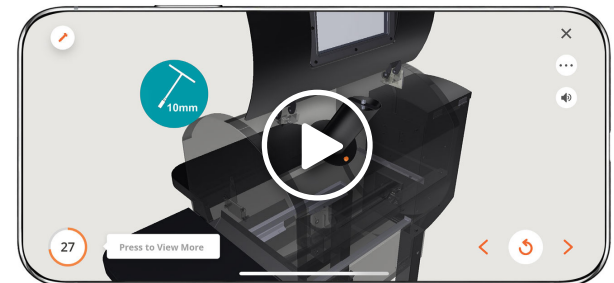

BEST VALUE & PREMIUM QUALITY
HARDWOOD PELLETS

GMG continues to bring its pellet game with four blends of 28lb bags of pellets that match up for anything you want to cook. Our pellets are the top in the industry because we focus only on hardwoods, debarked logs and low dust. We use 100% kiln-dried sawdust that never touches the floor. Our pellets are held together by the natural lignins in the wood and are a larger diameter pellet that allows them to last longer than standard size pellets. While our competitors continue to use soft woods and shrink their bags, we are giving you the best species of hardwoods and more pellets at a better price.



GOLD

28 LBS

RED OAK
 AMERICAN HICKORY
 MOUNTAIN MAPLE



FRUITWOOD

28 LBS

ORCHARD CHERRY
 AMERICAN BEECH
 SWEET PECAN



TEXAS

28 LBS

BLACK OAK
 AMERICAN HICKORY
 TEXAS MESQUITE



APPLE

28 LBS

RED OAK
 AMERICAN HICKORY
 APPLE WOOD



GMG US REGIONAL
PELLET BLEND CHOICE

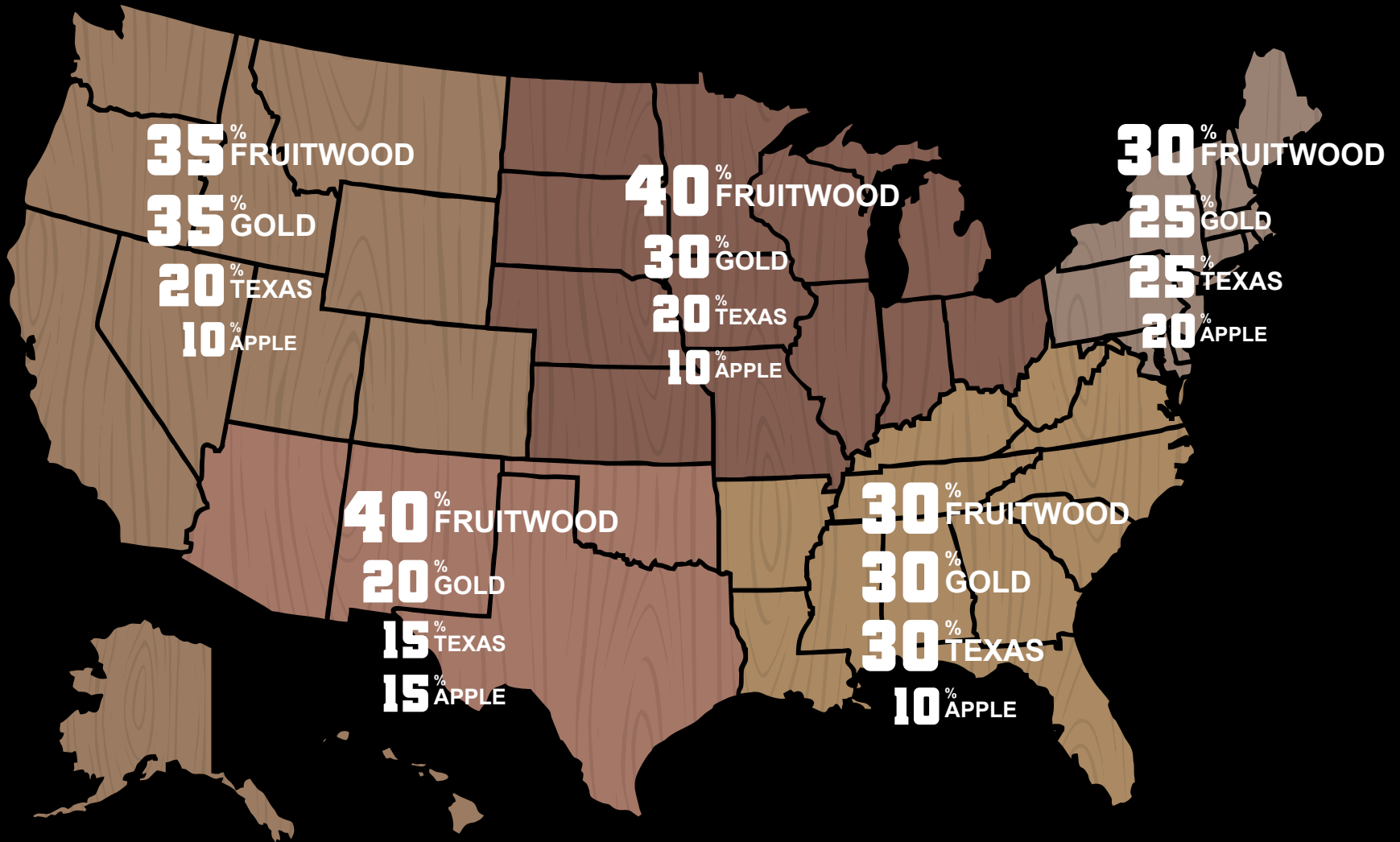

ELEVATED PRIME 2.0
PRODUCT PACKAGING

Simple, bold, & purposeful design.

The basis behind not only our product design but also our packaging.

